

Parts Listing for Single Section Station

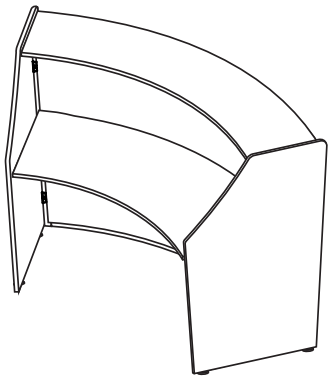
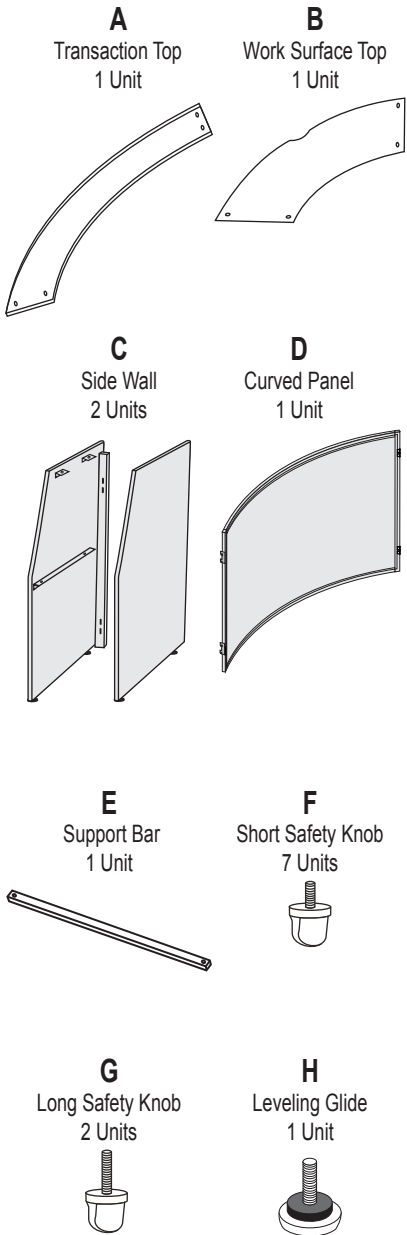

Assembly Instructions

Please read all instructions before beginning.

NO TOOLS REQUIRED TO ASSEMBLE SINGLE SECTION STATION. Two people are needed for assembly.

- If you purchased models 55290 or 55310 (1 section) follow steps 1-3.
- If you already have an existing Marque Reception Station and are adding sections to it, follow steps 4 - 8.
- If you purchased models 55292 or 55312 (2 sections), 55293 or 55313 (3 sections), 55294 or 55314 (4 sections), 55296 or 55316 (5 sections), follow steps 1A, 6, 7 & 8.

Step 1A: Insert Leveling Glide (H) into base of Curved Panel (D) if not already attached. Stand Curved Panel (D) up with Leveling Glide on floor. While one person holds Curved Panel (D), place one Side Wall (C) alongside Curved Panel (D) as shown. Slide steel ears on the Curved Panel (D) into holes of vertical support beam attached to Side Wall (C) and force downward to lock panel.

Step 1B: Attach other Side Wall (C) as explained above.

Step 2: Place Work Surface Top (B) on top of horizontal support beams attached to the Side Walls (C). Attach Support Bar (E) from underneath by placing it diagonally from the front of one Side Wall (C) to the back of the other and secure with two Long Safety Knobs (G). Insert them through the Support Bar (E) and the horizontal support beams of the Side Walls (C) then into the bottom of the Work Surface Top (B). Use two Short Safety Knobs (F) to finish attaching Work Surface Top (B) by inserting them through remaining holes in the horizontal support beams of the Side Walls (C) and into the bottom of Work Surface Top (B) and tighten.

Step 3: Place Transaction Top (A) on support brackets attached to the top of each Side Wall (C) and secure using Short Safety Knobs (F) in all holes. Flip up center support tab on inside of Side Wall (C) and secure with Short Safety Knob (F). You can now tighten all knobs securely.

NOTE: Please see page 2 to continue assembly of Multi-Section Stations.

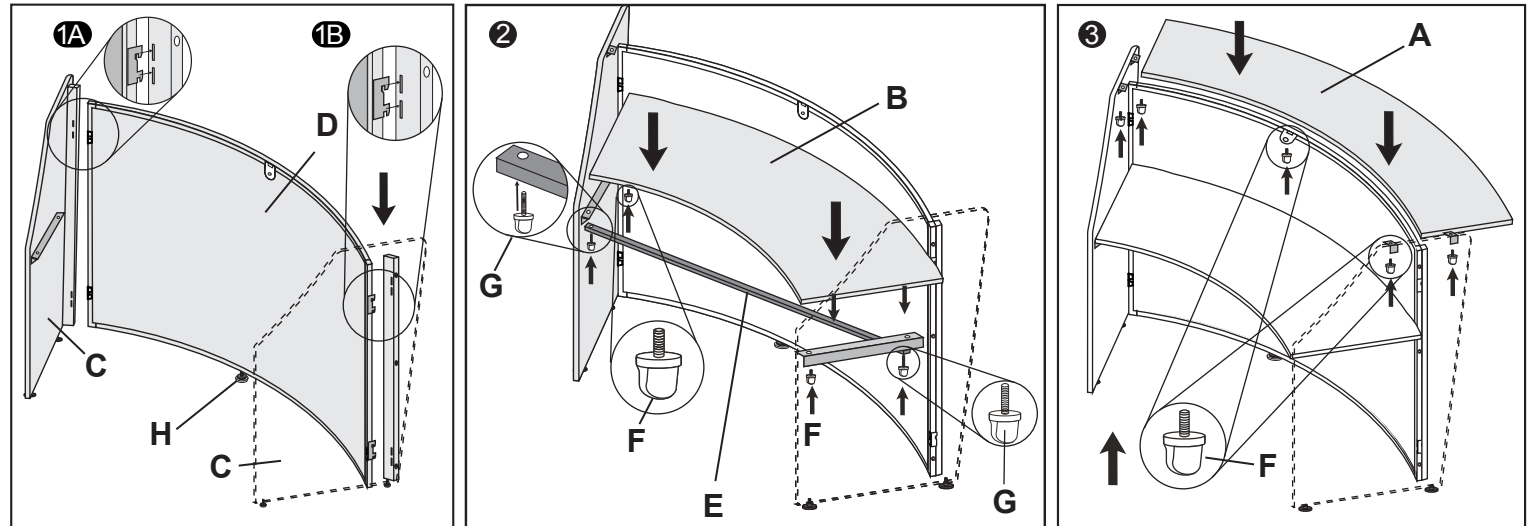

Assembly Notes:

During assembly, hand tighten screws only. When all screws are in place, you may then tighten all screws completely.

CAUTION:

1. Do not use this desk as a step ladder.
2. Check for loose screws and tighten them every 6 months.



161 Tradition Trail, Holly Springs, NC, 27540
 800-520-7471 (voice) • 919-362-4765 (fax)
 919-303-6389 (voice) • www.ofminc.com
 support@ofminc.com

Parts Listing for Multiple Sections

A
Transaction Top
1 Unit Per Section

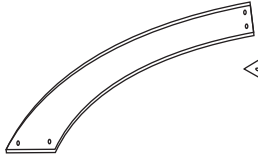

B
Work Surface Top
1 Unit Per Section



C
Side Wall
2 Units

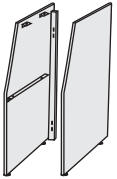

D
Curved Panel
1 Unit Per Section

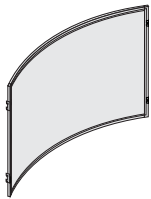

E
Support Bar
1 Unit Per Section



F
Short Safety Knob
7 Units Per Section



G
Long Safety Knob
2 Units Per Section



H
Panel Support
1 Unit Per Section

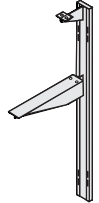

I
Connector Plate
1 Unit Per Section



J
Leveling Glide
1 Unit Per Section

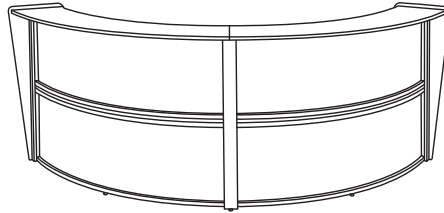

Assembly Instructions

Please read all instructions before beginning.

NO TOOLS REQUIRED TO ASSEMBLE

Two people are needed for disassembly and reassembly.

Note: It is important to build the Reception Station in the place it will be used as it is difficult to move after built.

- If you already have an existing Marque Reception Station and are adding sections to it, follow steps 4 - 8.
- If you purchased models 55292 or 55312 (2 sections), 55293 or 55313 (3 sections), 55294 or 55314 (4 sections), 55296 or 55316 (5 sections), follow steps 1A, 6, 7 & 8.

Step 4: Detach Transaction Top (A) by removing all 5 Short Safety Knobs (F) and placing them to the side for later use. Now detach Work Surface Top (B) by first removing the Support Bar (E). Remove the two Long Safety Knobs (G) first, then the Short Safety Knobs (F) and place them to the side for later use.

Step 5: Remove one Side Wall (C) by holding it tight and lifting upward on the Curved Panel (D). This will disengage the steel ears from the holes of the vertical beam attached to the Side Wall (C).

NOTE: Please see page 3 to continue assembly of Multi-Section Stations.

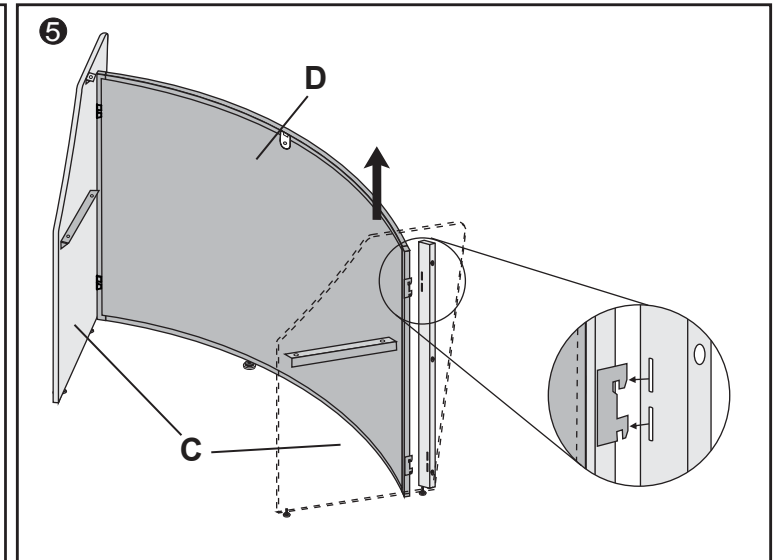
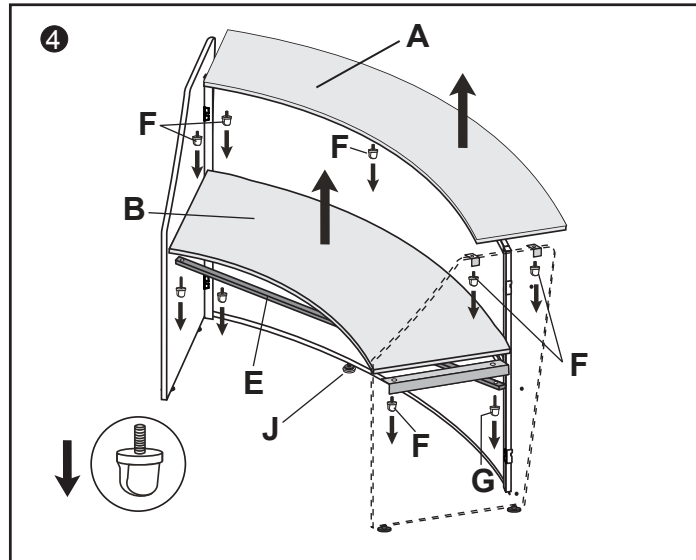

Assembly Notes:

During assembly, hand tighten screws only. When all screws are in place, you may then tighten all screws completely.

CAUTION:

1. Do not use this desk as a step ladder.
2. Check for loose screws and tighten them every 6 months.

ofm
Furniture For The Real Office™

161 Tradition Trail, Holly Springs, NC, 27540
800-520-7471 (voice) • 919-362-4765 (fax)
919-303-6389 (voice) • www.ofminc.com
support@ofminc.com

Assembly Instructions, continued

Please read all instructions before beginning.

NO TOOLS REQUIRED TO ASSEMBLE.

Two people are needed for **disassembly** and **reassembly**.

Note: It is important to build the Reception Station in the place it will be used as it is difficult to move after built.

- If you purchased models 55292 or 55312 (2 sections), 55293 or 55313 (3 sections), 55294 or 55314 (4 sections), 55296 or 55316 (5 sections), follow steps 1A, 6, 7 & 8.

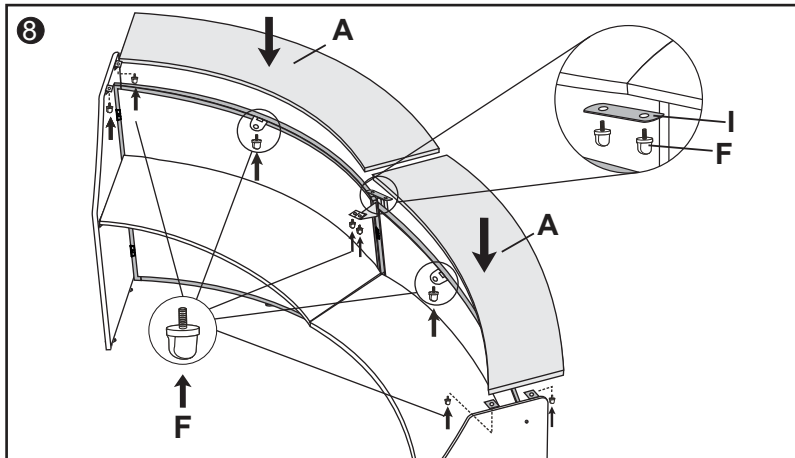
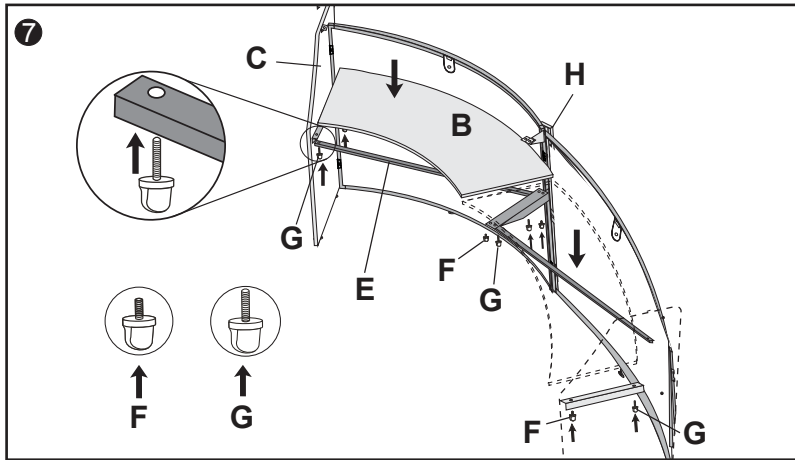
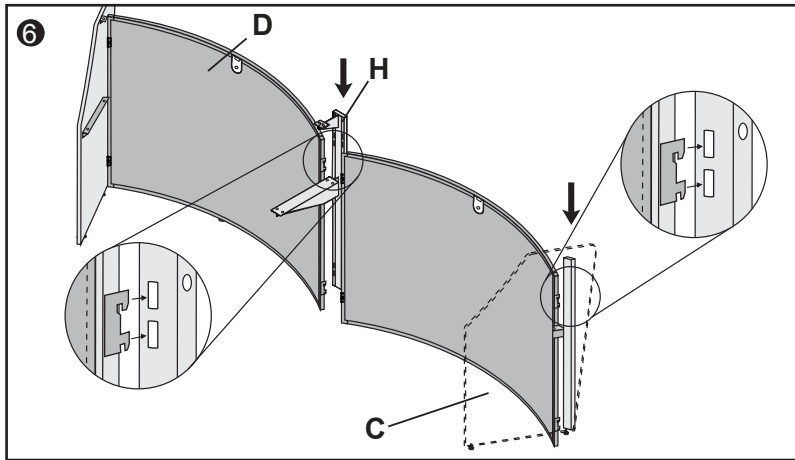

Step 6: Attach Panel Support (H) to Curved Panel (D) by placing support next to Curved Panel (D) and inserting the steel ears on Curved Panel (D) into holes of Panel Support (H) and pressing down on Curved Panel (D) to lock into place. Attach another Curved Panel (D) to Panel Support (H) and secure in same manner. **Repeat this step for as many sections as you have.** When all Curved Panels (D) are secured, attach the remaining Side Wall (C) to the last Curved Panel (D) by inserting the steel ears on Curved Panel (D) into holes of vertical support beam attached to Side Wall (C) and press down on Curved Panel (D) to lock it in place.

Step 7: Attach Work Surface Top (B) by placing it on top of Panel Support (H) and horizontal support beam attached to Side Wall (C). Attach Support Bar (E) from underneath by placing it diagonally from the front of Side Wall (C) to the back of Panel Support (H) and secure with two Long Safety Knobs (G). Insert them through Support Bar (E) and the horizontal support beams of the Side Walls (C) then into the bottom of Work Surface Top (B). Use two Short Safety Knobs (F) to finish attaching Work Surface Top (B) by inserting them through remaining holes in horizontal support beams of the Side Walls (C) and into the bottom of the Work Surface Top (B) and tighten. Repeat this step for as many sections as you have with the last Support Bar (E) and Work Surface Top (B) attaching to Side Wall (C).

Step 8: Place Transaction Top (A) on support brackets attached to top of Side Wall (C) and Panel Supports (H). Place 1 Connector Plate (I) under the Transaction Shelf (A) on the outside where 2 sections connect and align with holes in supports. Secure using Short Safety Knobs (F) in four holes. Flip up center support tab on inside of Side Wall (C) and secure with Short Safety Knob (F). **Repeat this step for as many sections as you have** with the last Transaction Top (A) attaching to the Side Wall (C). *You can now tighten all knobs securely.*

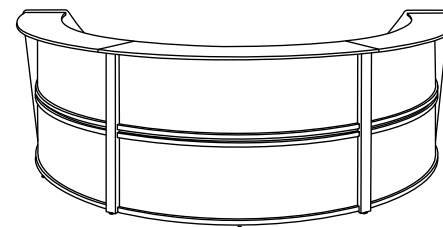

Three Section
Reception Station
Models 55293 & 55313

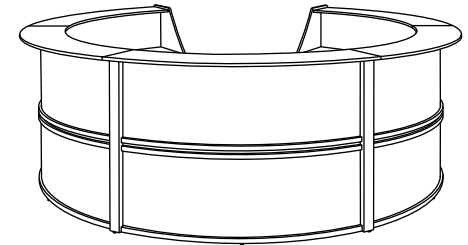

Five Section
Reception Station
Models 55296 & 55316